

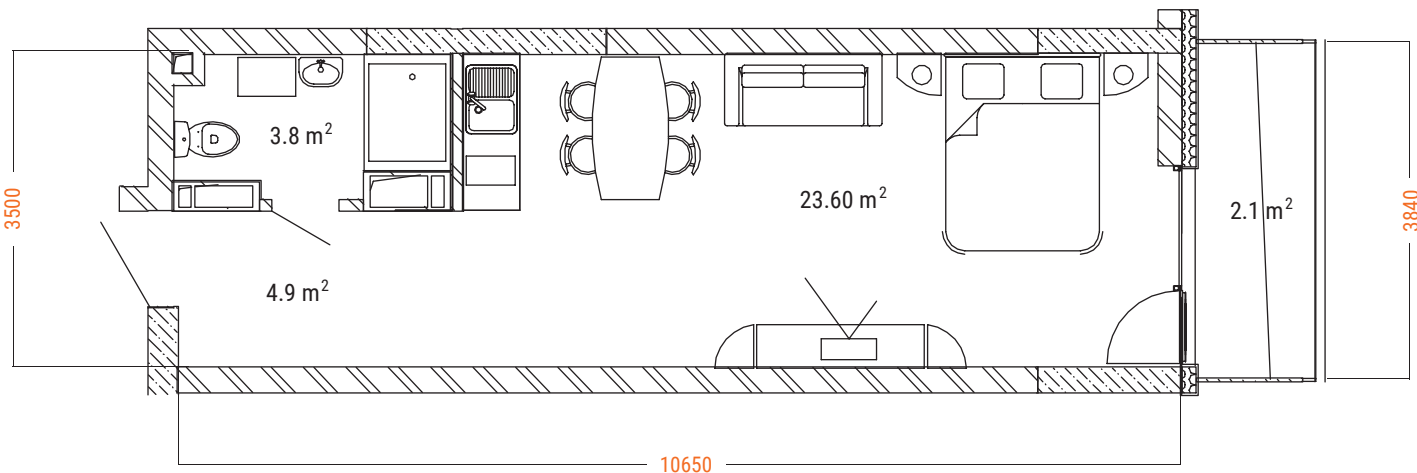

APARTMENT PLAN

TYPE 1G

34.40 m²



FLOOR PLAN

SECTION B



METRO STATION
«MINSKA»



METRO STATION
«OBOLON»

INFRASTRUCTURE

S1 OBOLON

METRO STATION
«HEROYV DNIPRA»



SHOPPING CENTER



SHOPPING CENTER



CAFE



CLINIC



RESTAURANT



RESTAURANT



CLINIC



CLINIC



SUPERMARKET



METRO STATION
«MINSKA»

STANDARD ONE



CAFE



SCHOOL



SCHOOL



SUPERMARKET



KINDERGARTEN



FITNESS CLUB



KINDERGARTEN



SCHOOL

SHOPPING CENTER



CINEMA



SCHOOL

KINDERGARTEN



ON FOOT



ON THE SUBWAY



10 MIN. PODIL



15 MIN. INDEPENDENCE SQUARE

MARSHAL TYMOSHENKO STREET

OBOLON AVENUE

MARSHAL MALINOWSKI STREET

METRO STATION
«OBOLON»



PRICE GROWTH CHART

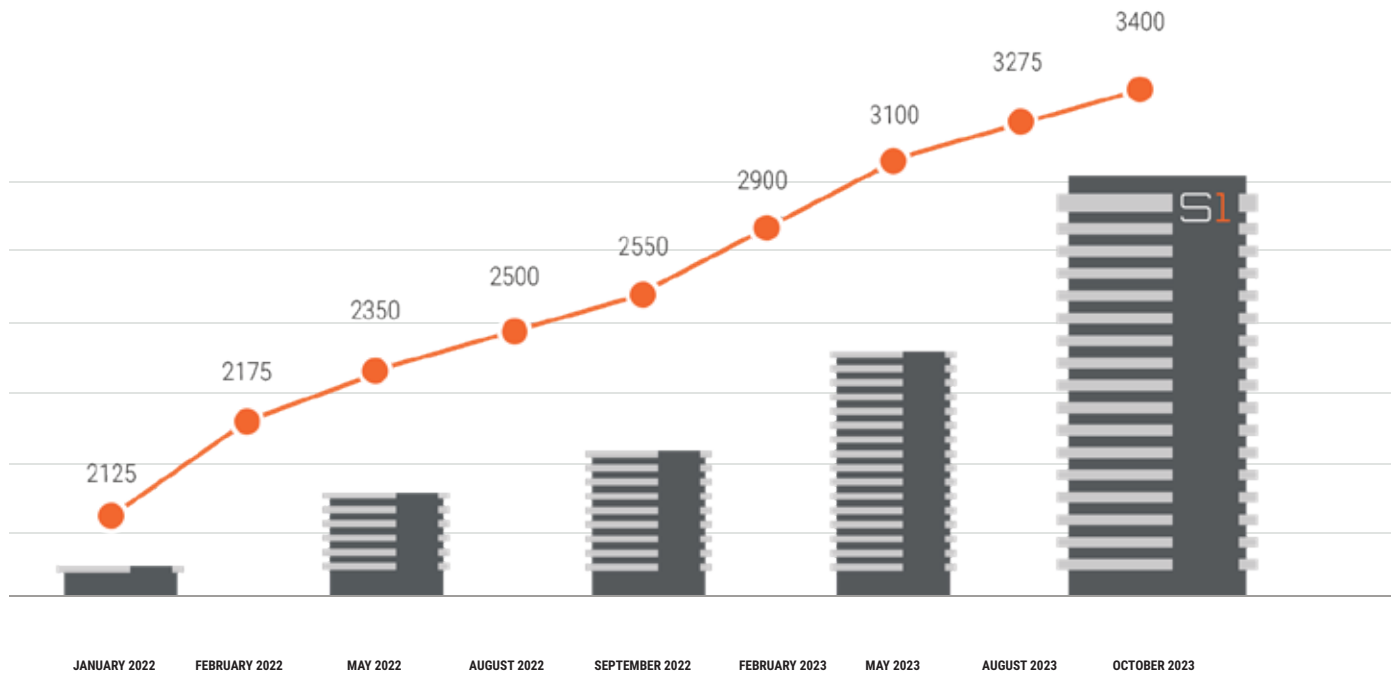

* THE EXPECTED FORECAST OF THE INCREASE IN THE VALUE OF SQ.M

MANAGEMENT MODEL AND PROFITABILITY

Area, sq.m.	34
Price for 1 sq.m.	\$2 125
Apartment cost	\$72 250
Rental income / month	\$680 - \$782
Management 10%	\$68 - \$78
Profit, 12 months	\$7 344 - \$8 446
Payback	8 - 10 years
Yield	10.2% - 11.7%

This calculation is for example, ask the current price of the apartment in the sales department.

ADVANTAGES

01

Studio apartments with «white box» renovation

03

Convenient location, 2 minutes to the Minska metro station, 15 minutes to the city center

02

Integrated real estate management and ecosystem for investors

04

Energy efficient technologies and environmental standards in construction

«White box» specification:

- finished walls
- finished floor (laminated)
- lighting and electrical fittings
- fully equipped bathroom
- entrance and interior doors
- air conditioning
- IKEA kitchen without appliances

SERVICES



MOBILE APPLICATION FOR APARTMENT MANAGEMENT



SECURITY 24/7



COWORKING AND LOUNGE AREA FOR RESIDENTS



CLEANING



YOGA STUDIO



PARKING WITH CHARGING FOR ELECTRIC CARS



CONCIERGE SERVICE



OWN RENTAL SERVICE